

---

# ELITE 700 SERIES

## INSTALLATION AND OPERATING INSTRUCTIONS

---



Copyright © 2002-2006, PRI Ltd. 9600-3005-2 Issue D

*Information contained within this document is subject to change without notice and does not represent a commitment on the part of PRI Ltd or its agents. E&OE.*

A307G09

### **IMPORTANT SAFETY INFORMATION**

This product is to be used to measure electrical quantities only when mounted in instrument panels, and is to be installed only by trained electricians and technicians.

Before energising the meter ensure that no stray strands of wire are present outside the connector blocks. As the Elite case is made from aluminium each meter must be connected to a good earth, using the stud provided.

Each Elite must be protected by fuses or voltage isolating links in each voltage circuit (see Section B).

There are no user-serviceable or installer-serviceable parts inside. Removing the cover with power applied exposes potentially hazardous voltages.

Under no circumstances may a current transformer (CT) be made open circuit when a current is flowing in the conductor to which it is fitted. The current input connector block supplied with Elite has automatic shorting links allowing the meter to be removed while the metered circuit is energised, however normal best practice must be used when fitting the cables from the CTs to the connector block during installation.

Elite meters contain a lithium battery that must be disposed of in a suitable manner at the end of the meter's life.

#### **CE MARKING DECLARATION OF CONFORMITY**

**Elite meets standard BS EN 610336:1997, and therefore conforms to EU Directive 89/336/EEC 'EMC Directive' as amended by 92/31/EEC and 93/68/EEC.**

---

### **SECTION A: INSTALLATION**

---

1. The meter fits into a DIN 96 square cut out (92 mm x 92 mm).
2. Remove the thumbscrews, then slide out the securing brackets from the rear panel.
3. Place the meter through the panel cut-out, then slide the securing brackets back into the slots on each side of the meter.
4. Tighten the thumbscrews so that the securing brackets bear on the rear of the panel into which the meter has been placed.
5. The current and voltage connectors are designed for cables up to 2.5 mm<sup>2</sup>, but can accept cables up to 4 mm<sup>2</sup> so long as the overall diameter is no greater than 5.0 mm. The pulsed output connector can accept cables up to 1.5 mm<sup>2</sup>.

*Excessive force can damage the meter. The thumbscrews only need to be 'finger-tight' to hold the meter in place.*

#### **Notes:**

1. For a 4-wire installation (Figs 1 & 2) the neutral must be connected, otherwise the meter will not function.
2. For a 3-wire installation (Figs 3 & 4) a single-phase unity power factor load will be reported as having power factor 0.866.
3. It is acceptable to common the 'S2' leads from the CT secondary terminals and connect them to earth.
4. The meter will automatically detect several types of connection fault (see Section C).

**PUBLIC**

## SECTION B: CONNECTIONS AND WIRING CONFIGURATIONS

The Elite rear panel houses connectors for voltage and current inputs, pulsed outputs and connections to factory-fitted modules for additional outputs or communications devices.

It is recommended that fuses or links be fitted in line with the voltage connections to enable meters to be removed safely without disconnecting the load from the supply. The current input connector is equipped with automatic shorting links, allowing the meter to be removed safely while the load is energised. For low voltage applications It is common practice, but not essential, to common together the secondary ('S2') connections from the external CTs and connect them to earth. For high voltage applications the secondary side of the external CTs must be earthed.

Elite is available in four wiring configurations to suit different applications:

Low Voltage

230 V phase to neutral, 3 phase 4 wire, CT operated  
 400 V phase to phase, 3 phase 3 wire, CT operated

High Voltage

110 V phase to phase, 3 phase 3 wire, CT and VT operated  
 63.5 V phase to neutral, 3 phase 4 wire, CT and VT operated

### SECTION B1: LOW VOLTAGE WIRING CONFIGURATIONS

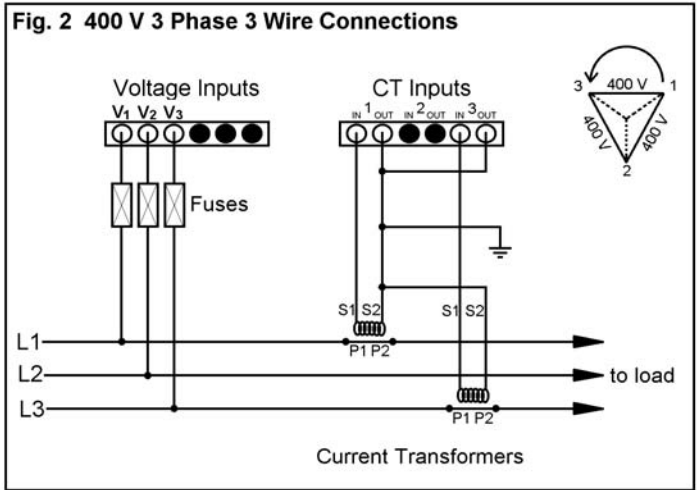
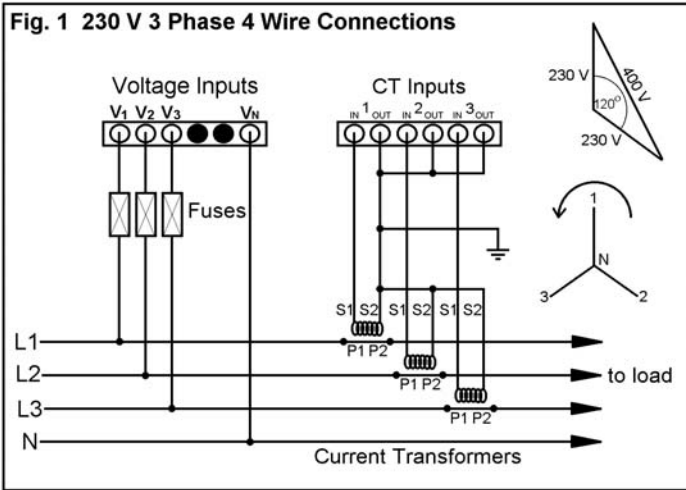

### SECTION B2: HIGH VOLTAGE WIRING CONFIGURATIONS

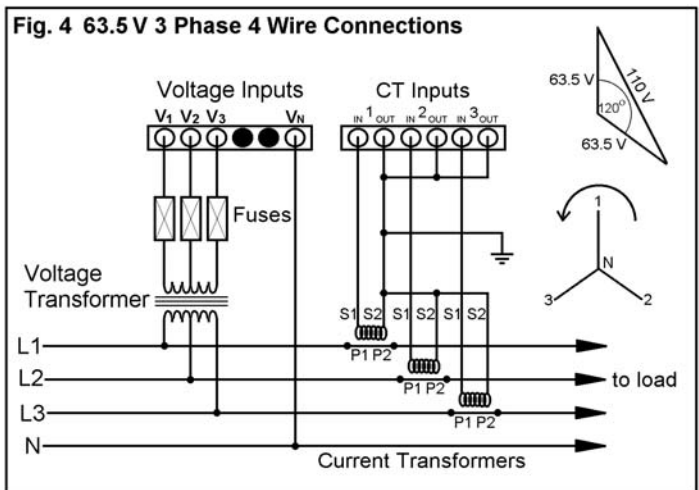
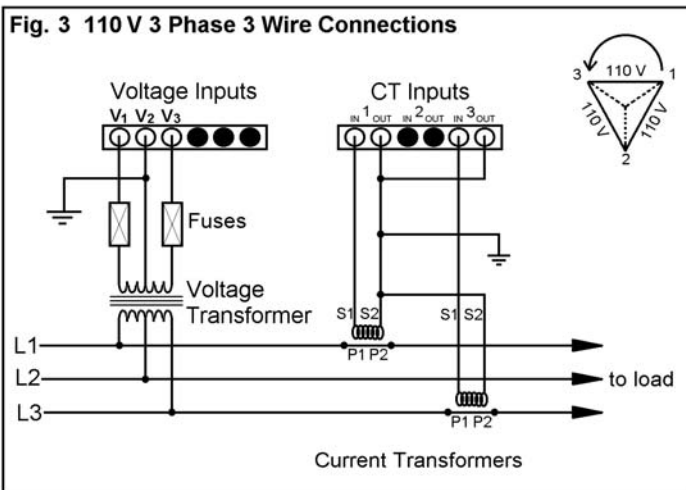

Special Note:

It is possible to correctly meter balanced high voltage three-phase three-wire installations using only one voltage transformer connection. This is done by applying the output from the VT to the red and blue inputs on the Elite. The yellow phase on the Elite is used as the reference in the usual way, and the same output from the VT is applied to both the red and the blue inputs on the meter. Two CTs are used. One CT is placed over the red phase and connected in the normal way to the red phase inputs on the Elite. Rather than using the blue phase, the second CT is placed over the yellow phase. The CT outputs are applied in reverse to the blue inputs on the Elite. The reversed connection establishes the correct phase relationship and can be achieved by placing the CT 'the wrong way round' over the feeder, and then connecting 'S1' to 'I<sub>IN</sub>' and 'S2' to 'I<sub>OUT</sub>' on the meter. Alternatively the CT can be placed over the feeder in the conventional way but with reversed connections to the meter; 'S1' to 'I<sub>OUT</sub>' and 'S2' to 'I<sub>IN</sub>'.

Fig. 5 Rear Panel Connections for Basic Elite

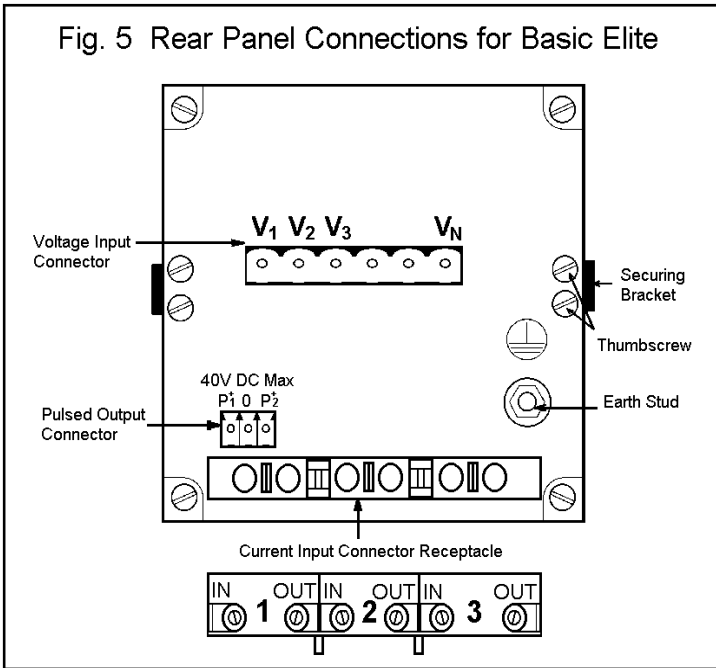
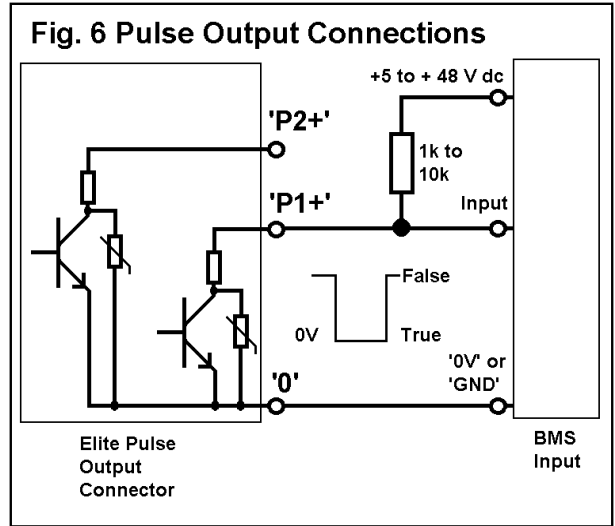

Fig. 6 Pulse Output Connections



The current and voltage connectors are designed for cables up to 2.5 mm<sup>2</sup>, but can accept cables up to 4 mm<sup>2</sup> so long as the overall diameter is no greater than 5.0 mm. The pulsed output connector can accept cables up to 1.5 mm<sup>2</sup>.

The maximum distance between the CTs and the meter is determined by the VA rating for the CT, the cable burden and the burden presented by the meter inputs. The burden for an Elite with 1 A inputs is 0.02 VA, or 0.3 VA for 5 A inputs. For more details refer to PRI document 9600-3001, 'Current Transformers Installation Guide'.

Fig. 7 Analogue Output Connections

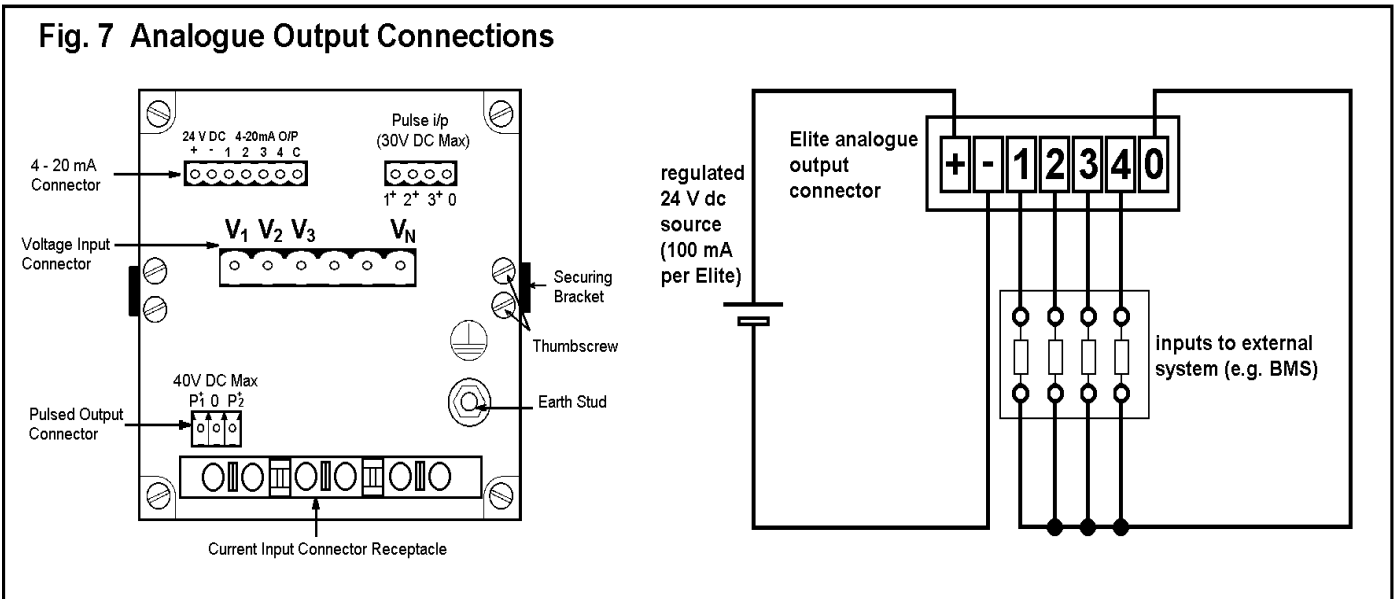

Elite models EL 70n1nn have four 4-20 mA analogue outputs. An external 24 V dc regulated 100 mA supply is required to drive the analogue outputs (e.g. RS 328-8427). Unregulated supplies are unsuitable because the output accuracy depends on a stable input voltage. A supply of greater capacity is needed if more than one Elite is to be powered.

The analogue output signals are intended for use with equipment having an input impedance in the range 100 to 1000 ohms. The analogue output signals are updated approximately once per second, and are derived from the corresponding displayed values.

The outputs are factory-set to kWh import, kVAh, kvarh import and voltage (average across the phases), but can be configured for different parameters (see Section E7).

**Fig 8. RS232 and RS485 MODBUS Connections**

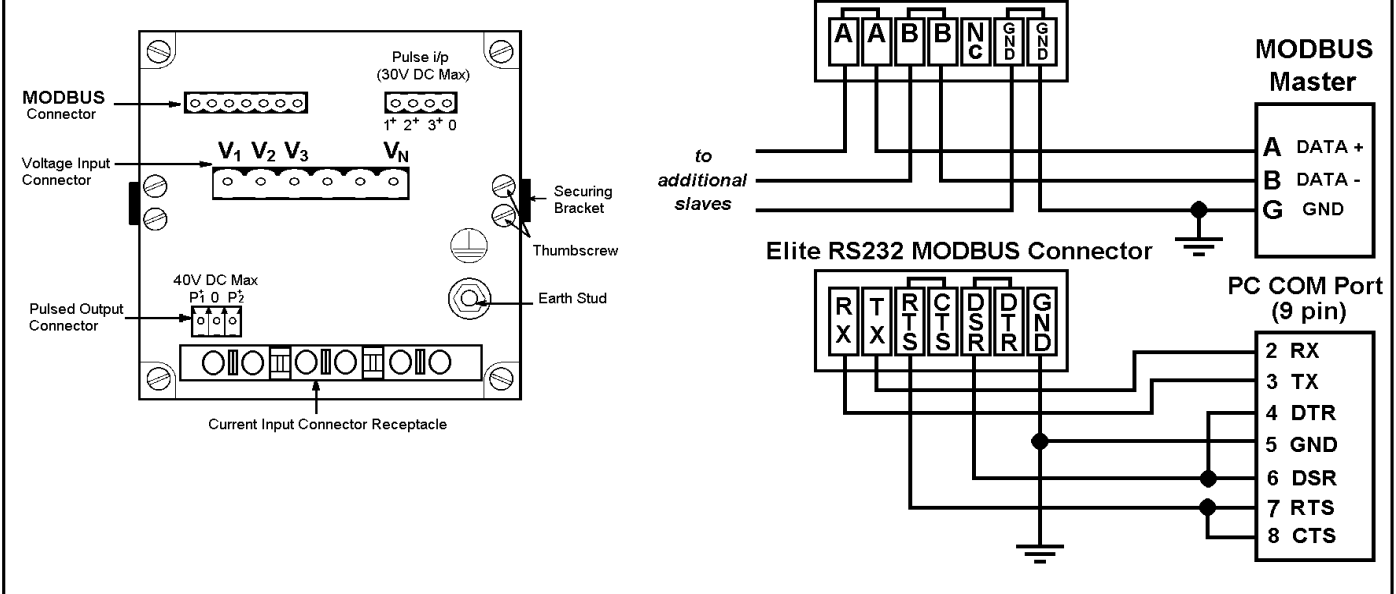

Elite models EL70n2nn have an RS-485 connector for MODBUS communications with an external master device, wired as a two wire system. Elite models EL70n4nn have an RS-232 connector for MODBUS communications with an external device such as a PC.

MODBUS RTU transmissions can be used to interrogate the Elite as a 'slave device' for any of the electrical parameters measured by the Elite. The device address and baud rate must be set up for each Elite (see Section E8). The message structure implemented in Elite is covered in PRI document 9600-3009, 'MODBUS Protocol & Register Map'.

The exact nature of the wiring is determined by the number of devices connected, the distance, the cabling used, and the electrical characteristics of the master and slave devices. It may be necessary to add terminating resistors or biasing resistors, for example. For very large systems it may be necessary to add repeater devices.

The use of port-powered RS232 to RS485 converters is not recommended.

The recommendations of the manufacturer of the MODBUS master 'device' should be followed.

**Fig. 9 Pulse Input Connections**

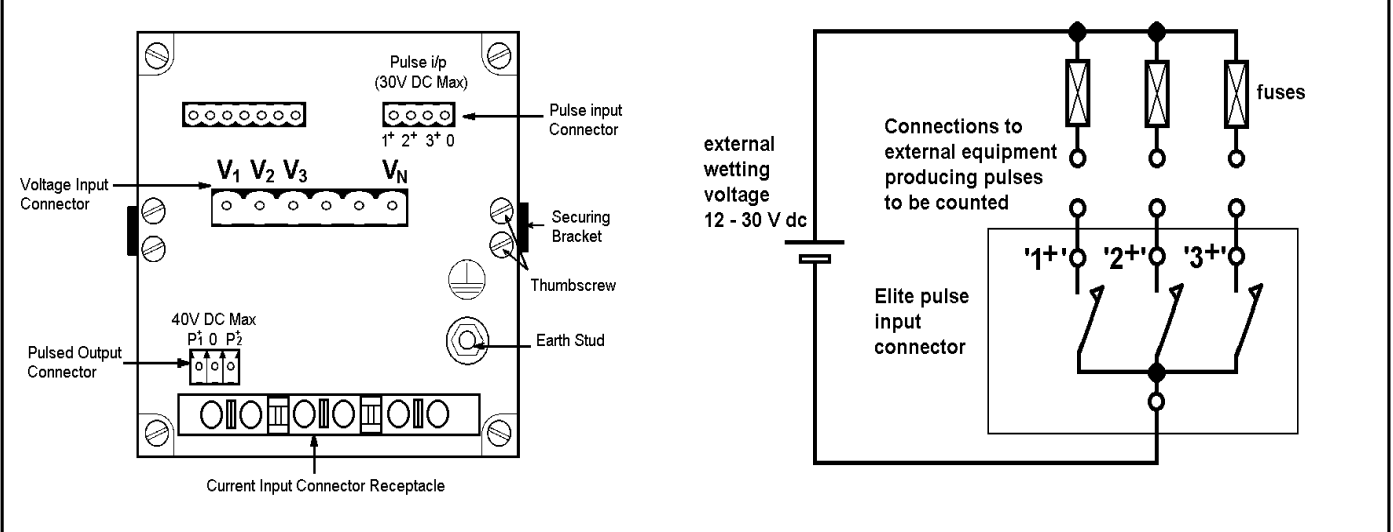

Elite models EL70n4nn have three pulsed inputs that can be used to count pulses generated by external equipment such as gas or water meters. By default, Elite EL70n4nn meters log half-hourly load survey values for four channels: kWh consumed (as measured by the Elite), pulse input 1, pulse input 2 and pulse input 3. EL70n4nn meters store load survey values for the most recent 29 days. All other Elite models are set by default to log only one channel; kWh consumed (as measured by the Elite). Load survey values for the most recent 118 days are stored.

An external wetting voltage (12 to 30 V dc) must be provided for the pulsed inputs. Polarity must be observed; the common connection must be at lower potential than the connections for the individual inputs '1+', '2+' and '3+'. The pulse inputs can detect pulses of 30 ms or greater duration at a maximum input frequency of 10 Hz.

Pocket Power View and EASEii software can be used to interrogate Elites via the PACT port on the front of the meter. Load survey and instantaneous parameters can be retrieved. Elite meters can be configured to special order to log up to five energy channels (as measured by the Elite). Load survey data can be stored for any combination of active or reactive energy (import or export) and apparent energy. Elite models EL70n4nn can in addition be programmed to log any combination of the three pulsed inputs. The number of days' data that can be stored varies with the number of channels, from 118 days (1 parameter) down to 15 days (8 parameters).

## SECTION C: DIAGNOSTIC CHECKS

Elite meters continuously monitor voltage, current and phase angle for each phase, enabling a number of fault conditions to be detected during normal operation and also when the meter is first installed. During normal operation the diagnostic displays are available on 'Page 7'. Each time power is applied a full range of checks are performed, during which time the LCD panel shows a 'test pattern'. If multiple faults are present the most significant is shown first, with others presented in order as the more significant faults are cleared.

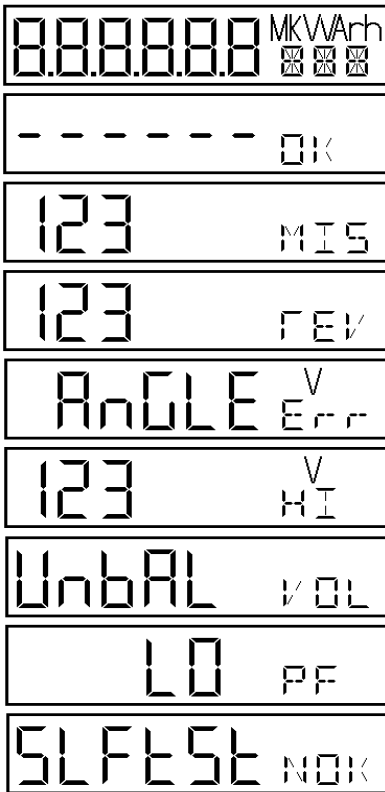

Test Pattern; all segments illuminated.

Diagnostic Checks OK; no faults found.

Phase missing; any phases below 20% nominal voltage are indicated by 1, 2 and 3 for L1, L2 and L3 respectively. 3-phase 4-wire meters can operate so long as any one or more phases and neutral are present. 3-phase 3-wire meters require L2 and either L1 or L3 to be present.

Phase reversed; indicates any phases with a CT connected with incorrect polarity. This test is not performed if the current is below 10% of the rated value.

Phase angle incorrect; this is shown if the angle between any two connected phases is outside  $\pm 10^\circ$  degree limits, or if the phase sequence is reversed.

Over Voltage; this is displayed if any of the connected voltages exceeds 130% of the nominal value.

Unbalanced Voltage; this is determined dynamically if any voltage is outside the  $\pm 10\%$  band centred on the mean value of the three phases.

Low Power Factor; this is displayed if the average power factor is less than 0.5.

Self-Test Failure; this display is shown if the meters fails its diagnostic checks. The meter should be returned to the supplier for repair.

## SECTION D: ELITE FRONT PANEL FEATURES

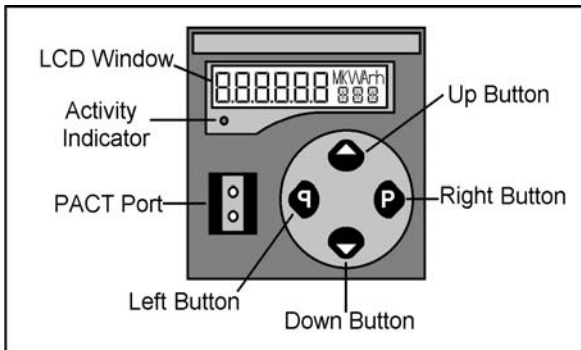

The LCD window is used to display metering data, configuration settings and diagnostic information.

The Activity Indicator flashes at a rate proportional to the consumed active power (kW import).

The PACT port can be used to access instantaneous electrical parameters using PRI or third party software.

The push buttons are used to select display items, change meter configuration, and to select different operating modes.

### Normal Operation

The parameters that can be displayed by Elite are grouped in 'pages', the content of which varies between different models (see Section F). The *left* and *right* buttons are used to select which page is to be shown. The right button moves to the 'next' page; the left button returns to the 'previous' page. The *up* and *down* buttons are used to scroll through the current page.

### Set-Up Mode

Various configuration items can be changed to match the Elite to a particular installation. The items that can be altered vary according to the model (see Section F). Holding in the *up* and *down* buttons together for five seconds accesses 'Set Up' mode. The LCD counts down from 5 to 0 before 'Set Up' mode is engaged (See Section E).

### Resetting Maximum and Minimum Values

Elite meters continuously monitor the maximum and minimum values observed for various electrical parameters (see Section G). The maximum and minimum values can be reset by holding in the *up* and *right* buttons together for five seconds. The LCD counts down from 5 to 0 before resetting the values.

### Billing Operation for Tariff Rate and Maximum Demands

Elite 708 models include time of use (TOD) rate and maximum demand (MD) functions (see Section E3). A billing operation can be performed on these registers by holding in the left and right buttons together for five seconds. This causes the contents of the rate and MD registers to be copied to their corresponding billing registers; the MD registers are then reset.

**Special Note: Elite meters are not approved by OFGEM for billing purposes, therefore any financial significance attached to metering data derived from an Elite is not enforceable in UK law.**

## SECTION E1: SET UP MODE

All Elite meters are supplied with factory settings that may need to be altered to suit a particular installation. The model and the wiring configuration determine the parameters that can be changed, as shown in the table right.

Configuration Parameter	Elite Model
Primary Current	All models.
Primary Voltage	HV models only; 3-Phase 3-Wire 110 V p-p
TOD Configuration: number of rates and times	EL708nnn only
Pulse Parameter	All models
Pulse Width	All models
Pulse Value	All models
Analogue Output Parameters	EL70n1nn only
MODBUS slave address	EL70n2nn only
Favourites Page	All models



The configuration of the meter may be changed by following the sequence below:

1. With power applied to the meter hold in the *up* and *down* buttons together for five seconds. The display indicates that 'Set Up' mode has been selected, then counts down from 5 to 0, as shown in the right hand section of the LCD. The buttons must be released when the count-down reaches zero.
2. Header displays are used to differentiate between the parameters that can be altered. The *right* button is used to move on to the next commissioning item. Note that this process only works in strict sequence; it is only possible to go back and alter a parameter by re-entering set up mode by holding in the *up* and *down* buttons.

The header displays for the various configuration parameters are shown below:

Primary voltage  
(HV models only).

Primary current.

Number of TOD tariff rates.

End time for indicated TOD  
tariff rate register.

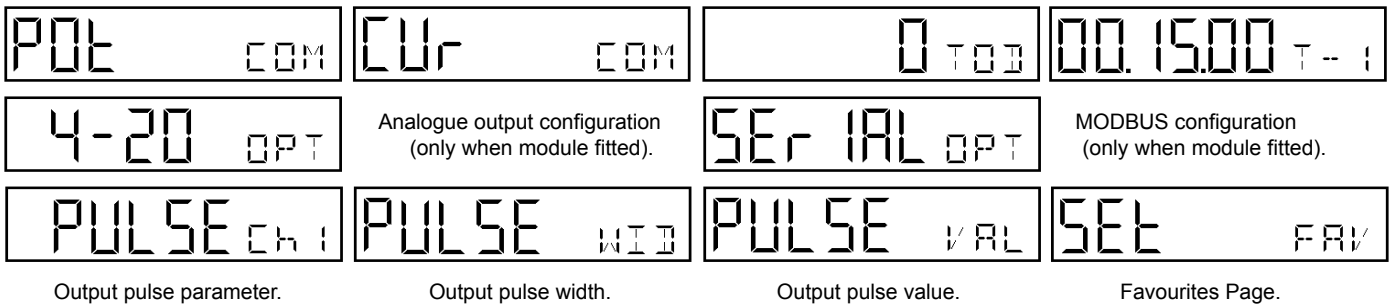

Output pulse parameter.

Output pulse width.

Output pulse value.

Favourites Page.

Pressing the *down* button selects the parameter currently being displayed. The *right* button moves on to the next one in the sequence.

**SPECIAL NOTE:** Pressing the *down* button while any of the above headers is being displayed causes the related parameter to be reset to the factory default value. It is best to use the Configuration Displays in Page 7 (see Section G) to check the set up.

## SECTION E2: CHANGING PRIMARY CURRENT AND VOLTAGE SETTINGS

Pressing the *down* button while the display is showing the primary current or primary voltage header resets the parameter to its default value (e.g. 5 A primary current for an EL707025). The required value can then be set by pressing the *down* arrow to increase it or the *up* arrow to decrease it. When the required value has been entered press the *right* button to commit it to memory.

**SPECIAL NOTE:** Do not attempt to configure primary current or voltage values on Elite meters that have been 'factory set' to values that cannot be accessed in 'set up mode' (e.g. 225 A, 10 kV).

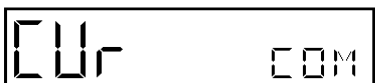

To change the primary current press the *down* button while this display is showing.

The primary current is then reset to the default value (5 A for an Elite with 5A CT inputs).



Pressing the *down* button increases the primary current in 5 A steps up to 100 A, then 10 A steps up to 200 A, then 50 A steps up to 2000 A, then 100 A steps up to 9900 A.



Pressing the *up* button decreases the primary current, using the same steps given above.



Pressing the *right* button causes the selected primary scaling value to be committed to memory. This takes around five seconds, due to the complex calculations involved, during which time the Elite flashes the following message on the display:

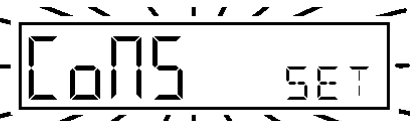

For VT connected meters a similar process can be used to set the primary voltage to one of the following values: 110 V, 1.1 kV, 2.2 kV, 3.3 kV, 6.6 kV, 11 kV, 13.2 kV, 16.5 kV, 22 kV, 24kV, 33 kV, 36.3 kV, 66 kV, 110 kV, 132 kV, 145.2 kV, 220 kV. Note that both primary current and primary voltage need to be set for VT connected meters; entering 'set up mode' for voltage resets the current value to default.

Elite automatically moves on to the next commissioning setting (e.g. pulse width) when the value has been stored in memory.

## SECTION E3: CHANGING TOD TIMES (EL708 ONLY)

Model EL708 Elite meters can be configured with up to 8 time-of-use (TOD) zones for energy and maximum demand operation. For each zone three separate energy registers (kWh import, kWh export, kVAh) and two separate maximum demand registers (kW import and kVA) are automatically set up. When a billing operation is performed the contents of the energy and maximum demand registers are copied into the corresponding 'billing' registers. The billing registers are 'frozen' at their new values until the next billing operation occurs. Energy registers are never reset; they continue to increment within the current billing period from the value attained when billing occurs. Maximum demand registers for the current billing period are reset as part of the billing operation. The time reference in the Elite is set at manufacture to GMT (standard time) with no adjustment for BST (daylight saving time), and is backed up by battery when the meter is not connected to mains voltage. The shelf-life is in excess of two years. There is no drain on the battery when the meter is connected to mains voltage.



To set up the number of TOD zones and their timings press the *down* button while this display is showing in Set Up mode.

Successive presses of the *down* button increase the number of TOD zones, up to a maximum of eight.



(Note: Pressing the *up* button reduces the number of TOD zones).

*This example shows a two-rate 'day and night' tariff being set up, where Rate 1 is active from midnight to 7 am, and Rate 2 from 7 am to midnight.*



When the required number of TOD zones has been selected, press the *right* button to commit the number to memory and move to the next Set Up stage.



To adjust the end times for the selected TOD zones press the *down* button while this display is showing in Set Up mode.

Successive presses of the *down* button increment the end time for the indicated TOD zone by fifteen minutes. (The *up* button decrements time). Time zones can therefore only begin and end on the hour, quarter-hour or half-hour. The meter automatically sets the end time of the highest numbered zone to midnight.



When the end time for the second-highest numbered zone has been selected press the *right* button to commit the settings to memory and move on to the next Set Up stage.



## SECTION E4: PULSED OUTPUT PARAMETER SELECTION

Elite meters are fitted with two solid-state volt-free pulsed outputs for the purpose of indicating the passage of energy to external devices such as building management systems. Elite meters are configured at manufacture with output 1 set to indicate consumed active energy (import kWh) and output 2 set to indicate apparent energy (kVAh). The pulse width can be set to either 80 or 240 ms (see Section E5). The value of each pulse (units per increment) is determined by the rated power setting of the meter and the multiplier setting (see Section E6).

Output pulse parameters can be selected when the Pulse Channel header is displayed. Output pulses can be set to consumed active energy (import kWh), generated active energy (export kWh), apparent energy (kVAh), lagging reactive energy (import kvarh) or leading reactive energy (export kvarh).



To change the output pulse parameter selection for output 1 press the *down* button while this display is showing.

Press the *right* button to select kWh consumed.



Or press the *down* button then the right button to select kWh generated.



Or press the *down* button again then the right button to select kVAh consumed.



Or press the *down* button again then the right button to select kvarh consumed.



Or press the *down* button again then the right button to select kvarh generated.



To change the output pulse parameter selection for output 1 press the *down* button while this display is showing. The selection is made in the same way as for output 1.

## SECTION E5: CHANGING PULSE WIDTH

Elite meters are fitted with two volt-free pulsed outputs that emit pulses to indicate consumed active and apparent energy (import kWh and kVAh) as factory default settings. The output parameters can be selected within 'Set Up' mode (see Section E4). The pulse width may be set to either 80 ms or 240 ms by pressing *the down* button when the Pulse Width header is displayed:



To change the pulse width press the *down* button while this display is showing.

Press the *right* button to select 80 ms pulse width.



Or press the *down* button then the *right* button to select 240 ms.



## SECTION E6: CHANGING PULSE VALUE

At any given primary scaling of an Elite there are four alternative pulse values. The pulse value determines the 'units per pulse' for each pulse seen across terminals P1+ and 0, and between P2+ and 0 on the output connector. The table shows the choices for various rated power values. The same magnitude applies to all energy types, so a 'x1k' multiplier produces 'x1 kVAh' or 'x1 kvarh' pulses, and so on.

Power Range (At primary scaling)	Pulse value with x1 multiplier	Pulse value with x10 Multiplier	Pulse value with x100 multiplier	Pulse value with x1000 multiplier
1 W to 555 W	1 Wh	10 Wh	100 Wh	1 kWh
556 W to 5.55 kW	10 Wh	100 Wh	1.0 kWh	10 kWh
5.56 kW to 55.5 kW	100 Wh	1.0 kWh	10 kWh	100 kWh
55.6 kW to 555 kW	1.0 kWh	10 kWh	100 kWh	1 MWh
556 kW to 5.55 MW	10 kWh	100 kWh	1 MWh	10 MWh
5.56 MW to 55.5 MW	100 kWh	1 MWh	10 MWh	100 MWh
55.6 MW to 555 MW	1.0 MWh	10 MWh	100 MWh	1 GWh
556 MW to 5.55 GW	10 MWh	100 MWh	1 GWh	10 GWh

**MAX 40V DC**

P1<sup>+</sup> P2<sup>+</sup>

Pulses indicating metered energy units are emitted between P1 and 0, and P2 and 0. The polarity must be observed when connecting to a wetting voltage or to test equipment (e.g. a DVM).

The power level for a given installation can be determined by multiplying together the primary voltage and current for each circuit. Note that a three-phase meter with only one or two phases connected is treated as if all three phases were connected for these purposes.

Example: 230 V 3-phase 4-wire meter with 200 A CT primary scaling.

$$\begin{aligned} \text{Power rating} &= 230 \text{ V} \times 200 \text{ A} \times 3 \\ &= 138,000 \text{ W} \\ &= 138 \text{ kW} \end{aligned}$$

**Maximum rating for the pulsed output is 100 mA at 40 V d.c. As the output is open-collector type the common '0' connection must be taken to a less positive point than 'P1+' and 'P2+'.**



To change the pulse value press the *down* button while this display is showing.

The options available are determined by the power rating as given in the table above. This example is for a 3p 4w 230 V Elite with 200 A primary current (138 kW power rating).

Press the *right* button to select x1 multiplier



Or press the *down* button then the *right* button to select x10 multiplier



Or press the *down* button again, then the *right* button to select x100 multiplier



Or press the *down* button again, then the *right* button to select x1000 multiplier



## SECTION E7: ANALOGUE OUTPUT PARAMETER SELECTION

Elite models EL70n1n have four 4-20 mA analogue outputs configured at manufacture to kW, kVA, kvar and average voltage. Each output can be set to any one of thirteen parameters available from within Set Up mode. The table below indicates the available parameters and details the minimum, mid-point, and maximum current output values for each.

Parameter	4 mA Output	12 mA Output	20 mA Output
Power (active, reactive or apparent)	Zero	50 % kWmax	kWmax
Frequency	45 Hz or less	50 Hz	55 Hz or greater
Average power factor across the phases	0.0 Leading	Unity	0.0 Lagging
Voltage (average across the phases, or per individual phase)	70 % Vnom	Vnom	130 % Vnom
Line Current (average across the phases, or per individual phase)	Zero	60 % Inom	Imax or greater

Definitions:

Inom = primary current corresponding to the nominal secondary current, e.g. 100 A for a 100/5 A or 100/1 A meter.

Imax = primary current corresponding to the maximum secondary current, e.g. 120 A for a 100/5 A or 100/1 A meter.

Vnom = nominal operating voltage, e.g. 230 V or 11kV

kWmax = power at 130 % nominal voltage and Imax, e.g. 3 x 299 V x 120 A = 108 kW for 3P 4W 230 V 100 A meter, or 1.732 x 14.3 kV x 600 A = 14.86 MW for 3P 3W 11 kV 500 A meter

Note:

Output current values for average current, average voltage and average power values are all based on three-phase operation. If fewer phases are present the output currents will be correspondingly lower.

The factory defaults parameter assignments are as follows:  
 Channel 1: Active Power; Channel 2: Apparent Power; Channel 3: Reactive Power;  
 Channel 4: Average Voltage.

To configure the analogue outputs press the *down* button while this display is showing. The *up* and *down* buttons are used to cycle through the available parameters. The *right* button is used to assign the currently displayed parameter to the current analogue output, and to move to the next analogue output.

*Example: Assigning Apparent Power to Channel 1*

Use the *down* button to scroll through the available parameters, firstly Active Power:

Press the *down* button again for Reactive Power:

Press the *down* button again for Apparent Power, then press the *right* button to assign the parameter to Channel 1. The Set Up process then moves on to Channel 2.

The parameters available for analogue outputs are presented in the following way:

Active Power	Reactive Power	Apparent Power	Frequency	Power Factor	Average Voltage (across the phases)	
Average Current (across the phases)	Voltage Phase L1	Voltage Phase L2	Voltage Phase L3	Current Phase L1	Current Phase L2	Current Phase L3

## SECTION E8: CONFIGURING MODBUS OPERATION

Elite models EL70n2nn have a rear-mounted connector for MODBUS operation for interrogation of metering values by a master device. The Unit ID and the baud rate are configured within Set Up mode. The Unit ID can be set to any number in the range 1 to 247.

	To change the MODBUS Unit ID press the <i>down</i> button while this display is showing.
	The <i>up</i> and <i>down</i> buttons are used to set the required address.
	Pressing the <i>right</i> button stores the current Unit ID in memory. Set Up mode then advances to baud rate selection.
	To change the MODBUS baud rate press the <i>down</i> button while this display is showing.
	The <i>up</i> and <i>down</i> buttons are used to toggle between 1200, 2400, 4800 baud. <i>Special Note: Elite models manufactured before June 2004 allow selection of 9600 bd, but this is not fully supported by the hardware. Do not select 9600 bd; the fastest supported baud rate is 4800.</i>
	Pressing the <i>right</i> button stores the current baud rate in memory.

## SECTION E9: CONFIGURING THE FAVOURITES PAGE

The metering information provided by Elite meters is grouped together in 'pages' which can be accessed using the four buttons on the front panel (see Section D). A special feature is provided by which the user can program a page of 'favourite' displays that can be readily accessed with the minimum of keystrokes. The Favourites Page is programmed from within 'Set Up' mode and enables up to 40 displays to be 'copied' from the default pages and 'pasted' in the order required. When programmed, Favourites Page appears as 'Page 1' in the sequence available when navigating using the *left* and *right* buttons.

From Set Up mode press the *right* button until the Set Favourites Page header is shown, then press the *down* button. This clears the Favourites Page ready to enter new displays.

Use the *right* and *down* buttons to navigate through the available display items. The display flashes to indicate that the meter is in the correct mode for setting up the Favourites Page. Use the *left* button to add the current display to the Favourites Page. The display stops flashing to indicate that the item has been added. Repeat this process until all the required items have been added, or until the maximum of 40 has been reached. Finally, hold in the *up* and *down* buttons together momentarily to exit 'Set up' mode.

*Example: Adding the display for Phase L1 to Neutral Voltage*

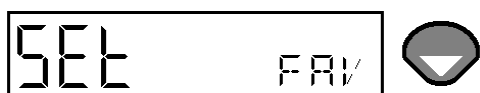

To configure the favourites page press the *down* button while this display is showing.

Any existing entries in the favourites page are cleared, and then the header for Page 2 is displayed, flashing.

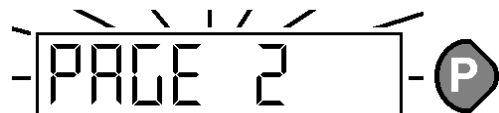

The display for phase L1 to neutral voltage is found in page 3, so the *right* button needs to be pressed to move to the Page 3 header.

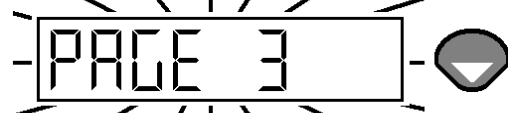

Press the *down* button to start scrolling through the available displays in Page 3.



Scrolling through Page 3 with the *down* button brings up the display for phase L1 to neutral voltage, as this is the first item within that page. Press the *left* button to add this to the Favourites Page. The display then stops flashing.

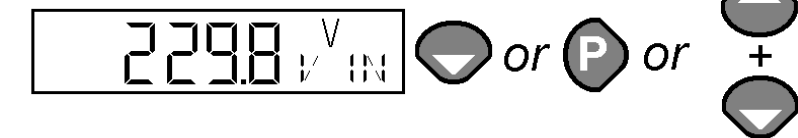

Press the down button to move to a different entry in Page 3, or press the right button to move to Page 4. When all the required displays have been copied into the Favourites Page, hold in the *up* and *down* buttons momentarily to exit 'Set Up' mode.

**Note: The operation of the buttons is subtly different when setting up the favourites page. The *up* and *down* buttons are used to navigate through the current page in search of the required displays. The *left* button is used only to paste the current display into the favourites page. The *right* button is used to move to the next page. Pressing in the *up* and *down* buttons together (momentarily) exits 'Set up' mode.**

## SECTION F: MODEL VARIANTS

There are two main Elite variants, with different features as detailed in the table shown right. The EL708 model has all the possible displays, supports two pulsed outputs and can be programmed with up to 8 time-of-use (TOD) tariff rate registers. The EL707 model also has two pulsed outputs, but supports fewer displays and does not have the TOD facility.

The table indicates which 'display page' each display appears in, as this varies between models.

Elites can be fitted at manufacture with one of three types of module providing extra functionality.

The fourth digit of the part number (e.g. EL707x25) indicates the type of module fitted, as given in the table below:

Fourth Digit of Part Number (e.g. EL 707x25)	Module Description
0	None. Basic Elite model.
1	Analogue Output Module, 4 off 4-20 mA outputs
2	RS-485 (MODBUS) and Logging Module
4	RS-232 (MODBUS) and Logging Module

Feature	EL707	EL708
Favourites Page	Page 1	Page 1
Test Pattern	Page 2	Page 2
Total kWh, kVAh, kvarh Import Displays	Page 2	Page 2
Total kWh and kvarh Export Displays	-	Page 2
Billing Registers for Import and Export Energy	-	Page 2
Elite Time and Date	Page 2	Page 2
Instantaneous kW, kVA, kvar Displays	Page 3	Page 3
Instantaneous Power Factor Display	Page 3	Page 3
Instantaneous Frequency Display	Page 3	Page 3
Instantaneous Voltage Displays	Page 4	Page 3
Instantaneous Current Displays	Page 4	Page 3
TOD Energy Registers and Billing Registers	-	Page 4
KW and kVA Maximum and Rising Demands	Page 5	Page 5
TOD Demand Registers and Billing Registers	-	Page 5
Maximum and Minimum Displays	Page 6	Page 6
Elite Configuration Displays	Page 7	Page 7
Elite Diagnostic Displays	Page 7	Page 7

## SECTION G: DISPLAY FORMATS

Elite meters have a single custom-manufactured LCD information window, programmed to show a range of information relating to the load that is being metered. To simplify access to particular information the displays are grouped in 'pages' accessed using the 'left' and 'right' buttons. The examples given below are for the EL708 model which features all possible displays. Models EL707 has less displays and fewer display pages; see Section F for details.

### Favourites Page

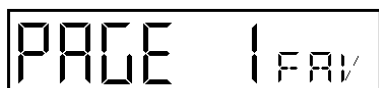

Header display for Page 1.

The contents of this page are determined by the user when the meter is set up (see Section E9).

## Test Pattern, Total Energies, Time & Date

Displays are shown for model EL708  
EL707 has fewer displays, arranged  
differently across the display pages.  
See Section F.

888888 MKVArh  
⊠ ⊠ ⊠

'Lamp Test' - all segments illuminated.

011763 KW h  
C I

Cumulative total register for kWh import, in this case showing 11763 kWh. The cumulative total registers are never reset, and are independent of any time of use (TOD) tariff that may have been set up.

000024 KW h  
C E

Cumulative total register for kWh export, in this case showing 24 kWh. (Not on model EL707).

019238 KVA h  
C

Cumulative total register for kVAh, in this case showing 19238 kVAh. Measurements of apparent energy and demand are active in all four quadrants.

014196 KV Arh  
C I

Cumulative total register for kVArh lag, in this case showing 14196 kvarh.

000459 KV Arh  
C E

Cumulative total register for kVArh lead, in this case showing 459 kvarh. (Not on model EL707).

011726 KW h  
B I

Billing register for kWh import, in this case showing 11726 kWh. The contents of the main energy registers are copied into the billing registers at each billing point. The billing registers remain 'frozen' at the most recently billed value until the next billing point. (Not on model EL707).

000024 KW h  
B E

Billing register for kWh export, in this case showing 24 kWh. (Not on model EL707).

019146 KVA h  
B

Billing register for kVAh, in this case showing 19146 kVAh. (Not on model EL707).

014117 KV Arh  
B I

Billing register for import kvarh (lagging for active import energy), in this case showing 14117 kvarh. (Not on model EL707).

000409 KV Arh  
B E

Billing register for export kvarh (leading for active import energy), in this case showing 409 kvarh. (Not on model EL707).

16.07.53 TIM

Meter time, in 24 hour format, here showing 7 minutes and 53 seconds past 4 pm. Note that the Elite time reference uses standard time (e.g. GMT) with no adjustment for summer time.

18.05.01 DAT

Meter date, showing 18th May 2001.

## Instantaneous Power, Power Factor, Frequency, Voltage and Current

003890 KW  
L O B

Instantaneous active power, here showing 3890 kW import (consuming). A minus sign is used to indicate active export (generating) power.

005480 KVA  
L O B

Instantaneous apparent power, in this case showing 54.80 kVA.

0038.50 KV Ar  
L O B

Instantaneous reactive power, here showing 38.50 kvar import (lagging for active consumption). A minus sign is used to indicate reactive export power (leading for active consumption).

0.718 PFA

Average instantaneous three-phase power factor. A '-' sign indicates 'leading' power factor. In this example the power factor is 0.718 lagging.

49.967 HZ

Instantaneous supply frequency, here showing 49.967 Hz.

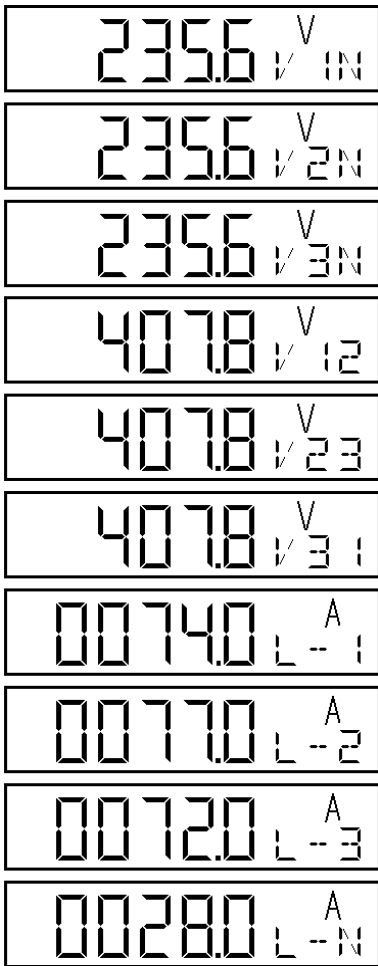

Instantaneous voltage, phase L1 to neutral, here showing 235.6 V.

**N.B. Phase to neutral voltages are not displayed on 3-phase 3-wire models**

Instantaneous voltage, phase L2 to neutral.

Instantaneous voltage, phase L3 to neutral.

Instantaneous voltage, phase L1 to phase L2, in this case showing 407.8 V.

Instantaneous voltage, phase L2 to phase L3.

Instantaneous voltage, phase L3 to phase L1.

Instantaneous line current for phase L1, in this case showing 74.0 A. The line current corresponds to the value that would be indicated by an external ammeter scaled to the same primary value and without reference to the voltage vector.

Instantaneous line current, phase L2.  
*(For 3-phase 3-wire meters this value is synthesized).*

Instantaneous line current, phase L3.

Instantaneous line current, neutral. This value is displayed only on 3-phase 4-wire models and is synthesized from the values observed on phases L1, L2 and L3.

### Time of Use (TOD) Registers - (Model EL708 Only)

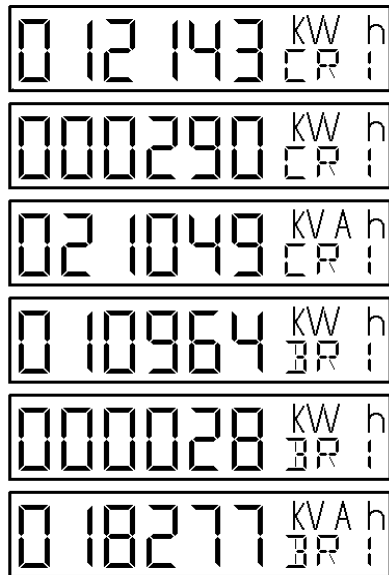

TOD register '1' for import kWh, in this case showing 12143 kWh. Up to eight TOD registers can be defined, identified as '1' through to '8'. The TOD energy registers are never reset. At the end of each billing period the values in these registers are copied into the corresponding billing registers.

TOD register '1' for kWh export, in this case showing 290 kWh. Note that it is only possible to distinguish between the kWh import and kWh registers by the sequence of the displays within this page.

TOD register '1' for kVAh, in this case showing 21049 kVAh.

**Note: Registers for the current active TOD rate are displayed flashing.**

Billing TOD register '1' for import kWh, in this case showing 10964 kWh. The billing registers reflect the contents of their respective TOD registers at the time of the last billing operation.

Billing TOD register '1' for export kWh, in this case showing 28 kWh. Note that it is only possible to distinguish between the kWh import and kWh registers by the sequence of the displays within this page.

Billing TOD register '1' for kVAh, in this case showing 18277 kVAh.

### Maximum Demand, Billing Demand and Rising Demand

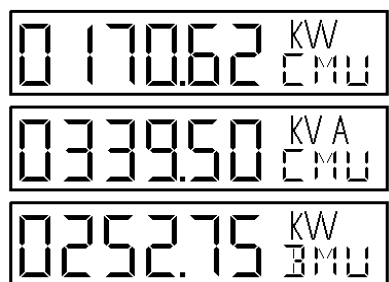

Current universal maximum demand register for kW import. This register operates continuously, 24 hours a day, and is independent of any TOD rate registers that may be operating.

Universal maximum demand register for kVA. This register operates continuously, 24 hours a day, and is independent of any TOD rate registers that may be operating.

*Note: At each billing point the contents of all the 'Current MD' registers are copied into their corresponding 'Billing MD' registers. The 'Current MD' registers are then reset.*

Billing universal maximum demand register for kW import. This contains the maximum value for kW import observed at any time (irrespective of TOD operation) during the previous billing period, if a billing operation has been performed.

039.137 KVA  
3MU

Billing universal maximum demand register for kVA. This contains the maximum value for kVA observed at any time (irrespective of TOD operation) during the previous billing period, if a billing operation has been performed.

0028.20 KW  
RO8

Rising demand registers for kW and kVA. These values are reset at the start of each half-hour demand integration period (DIP). At the end of each DIP the rising demand values are used to determine if new maximum values have been reached. The main display shows the rising demand values, in this case 28.20 kW and 36.60 kVA. The smaller display shows the number of minutes elapsed during the current DIP, in this case 8. It is therefore possible for the user to perform a simple calculation to determine the demand at the end of the current DIP, so long as the load is constant.

0036.60 KVA  
RO8

0170.62 KW  
CM1

Current 'Rate 1' 1TOD maximum demand register for kW import. The MD registers operate in parallel with the TOD rate registers for energy, so Rate 1 MD is active when Rate 1 TOD energy register is active, and so on. Up to eight TOD registers can be defined, numbered from '1' to '8'. (Not on model EL707).

0339.50 KVA  
CM1

Current 'Rate 1' 1TOD maximum demand register for kVA. Each TOD energy rate register has a pair of maximum demand registers operating in parallel; one for kW import and one for kVA. (Not on model EL707).

0252.75 KW  
3M1

Billing 'Rate 1' 1TOD maximum demand register for kW import. This contains the maximum value for kW import observed when Rate 1 was active during the previous billing period. Up to 8 such TOD registers can be defined, numbered from '1' to '8'. (Not on model EL707).

039.137 KVA  
3M1

Billing 'Rate 1' 1TOD maximum demand register for kVA. This contains the maximum value for kVA observed when Rate 1 was active during the previous billing period. Up to 8 such TOD registers can be defined, numbered from '1' to '8'. (Not on model EL707).

## Maximum and Minimum Values

250.8 V  
MX1

Maximum voltage recorded on phase L1 since last reset, in this case 250.8.  
(For 3-phase 3-wire meters the voltage for phase L1 to L2 is displayed).

249.7 V  
MX2

Maximum voltage recorded on phase L2 since last reset, in this case 249.7 V.  
(For 3-phase 3-wire meters the voltage for phase L2 to L3 is displayed).

248.3 V  
MX3

Maximum voltage recorded on phase L3 since last reset, in this case 248.3 V.  
(For 3-phase 3-wire meters the voltage for phase L3 to L1 is displayed).

220.2 V  
MN1

Minimum voltage recorded on phase L1 since last reset, in this case 220.2 V.  
(For 3-phase 3-wire meters the voltage for phase L1 to L2 is displayed).

222.3 V  
MN2

Minimum voltage recorded on phase L2 since last reset, in this case 222.3 V.  
(For 3-phase 3-wire meters the voltage for phase L2 to L3 is displayed).

223.6 V  
MN3

Minimum voltage recorded on phase L3 since last reset, in this case 223.6 V.  
(For 3-phase 3-wire meters the voltage for phase L3 to L1 is displayed).

1071.5 A  
MX1

Maximum current recorded on phase L1 since last reset, in this case 1071.5 A.

1049.7 A  
MX2

Maximum current recorded on phase L2 since last reset, in this case 1049.7 A.  
(For 3-phase 3-wire meters this value is synthesized).

1065.3 A  
MX3

Maximum current recorded on phase L3 since last reset, in this case 1065.3 A.

0000.1 A  
MXZ

Maximum zero-sequence current recorded since the last reset, in this case 0.1 A.

-0.986 CAP

Lowest capacitive (leading) power factor recorded since the last reset, in this case 0.986.

0.519 IND

Lowest inductive (lagging) power factor recorded since the last reset, in this case 0.519.

49.757 MNF

Minimum supply frequency recorded since the last reset, in this case 49.757 Hz.

0497.10 KW  
MX

Maximum active import power recorded since the last reset, in this case 497.10 kW.

0733.70 KVA  
MX

Maximum apparent power recorded since the last reset, in this case 733.70 kVA.

0539.50 KVAr  
MX

Maximum reactive (lagging) power recorded since the last reset, in this case 539.50 kvar.

### Diagnostic Displays and Configuration Items

----- OK

Diagnostic status. (See section C for details of the diagnostic conditions and the appropriate displays).

000800 MEN

Meter constant, showing the impulse rate of the flashing indicator, in this case 800 flashes per imported kWh.

4-20 OPT

SEr IAL OPT

Module fitment, in these examples showing that an analogue output (4-20 mA) module or an RS-485 (MODBUS) module is fitted.

bASE OPT

Module fitment, in this case showing that no module is fitted (base option).

011000 V  
PTP

Primary voltage setting, in this case 11 kV. This is only shown for HV meters.

110 V  
PTS

Secondary voltage setting, in this case 110 V. This is only shown for HV meters.

000100 A  
CTP

Primary current setting, in this case 100 A.

5 A  
CTS

Secondary current setting, in this case 5 A. Elites are supplied configured for connection to either 1 A or 5 A external current transformers (CTs).

07.00.00 T-1

End time settings for the TOD tariff rate registers defined in the meter (EL 708 only). Up to eight rates can be defined, identified by 'T-1' through to 'T-8'. The end time for TOD register '1' is the same as the start time for TOD register '2', and so on.

PULSE 1 W<sup>h</sup>  
IMP

Parameter assignment for pulsed outputs, in this case showing that Output 1 is set to active energy. The outputs are identified as 'PULSE1', 'PULSE2' etc. Note that this display does not indicate the magnitude of each pulse, only the type of energy assigned to the output.

0080 msc

Pulse width for the pulsed outputs, in this case showing 80 ms.

0001 K<sup>h</sup>  
VAL

Pulse multiplier for the pulsed outputs, in this case showing that each pulse represents 'x 1 k', so active energy pulses each represent 1 kWh apparent energy pulses represent 1 kVAh and so on.

Unit Id 001

Device ID for MODBUS operation, in this case showing ID '001'. This display is only shown only for Elites fitted with a MODBUS module.

4800 bps

Baud rate for MODBUS operation, in this case showing '4800'. This display is only shown for Elites fitted with a MODBUS module.

4-20C 1 A<sup>v</sup>  
AVE

Parameter assignment for analogue outputs, in this case showing that Channel 1 is set to average current. The channels are identified as 'C1', 'C2' and so on. These displays are shown only for Elites fitted with an analogue output module.