PREMIER

INSTALLATION AND OPERATING INSTRUCTIONS



Copyright © 2002 - 2006, PRI Ltd. 9600-3003-2 Issue C

Information contained within this document is subject to change without notice and does not represent a commitment on the part of PRI Ltd or its agents. E&OE.

IMPORTANT SAFETY INFORMATION

Care must be exercised during the installation of Premier meters and associated equipment due to the presence of mains voltages.

Local best practice and regulatory stipulations must always be observed.

Installation should only be performed by suitably trained personnel. Various points under the terminal cover operate at hazardous voltages.

Each Premier must be protected by fuses or voltage isolating links in each voltage circuit (see Section B). There are no user-serviceable or installer-serviceable parts inside. Removing the cover with power applied exposes potentially hazardous voltages.

Under no circumstances should the CT connections to the meter be disconnected while current is flowing in the primary circuit of the external CT. The CT connector is provided with retaining screws to reduce the possibility of accidental disconnection. It is good practice to ground the secondary connections ('S2') from the CTs.

After installation access to the connectors and conductors must be prevented by fitting the covers supplied, ensuring that they are secured in position with the screws provided and sealed in accordance with local practice

Suitable cabling must be used if mains voltages are to be connected to the input or output terminals. Double insulated cabling of at least 1mm² must be used.

CE MARKING DECLARATION OF CONFORMITY

Premier meets standard BS EN 610336:1997, and therefore conforms to EU Directive 89/336/EEC 'EMC Directive' as amended by 92/31/EEC and 93/68/EEC.

SECTION A: INSTALLATION

How to fix the meter in position

Premier meters are designed for vertical mounting, and can be fitted to meter panels, boards, enclosures or walls. Suitable screws must be selected to ensure a good fixture. Screws of up to M4 or 4BA size can be used.

Premier meters use a three-point fixing arrangement. The top screw is located on the meter's centre-line and fits into a 'key-hole' locator on the rear-plate of the meter. This screw supports the meter in position on the surface to which it is to be attached. Two other screws are fitted through the terminal block of the meter and are used to secure it against the mounting surface.

The fixing centres are as shown on this view of a Premier rear panel.

1. Mark out the position of the meter on the mounting surface, drill a hole and fit the top fixing screw.
2. Fit the Premier over the top fixing screw taking care to align it correctly within the 'key-hole' locator.
3. With the terminal cover removed, mark out the positions of the lower fixing screws.
4. Remove the meter, drill holes for the lower fixing screws.
5. Fit the meter over the top fixing screw again.
6. Fit the lower fixing screws

Note:

Sufficient space must be provided on all sides of the meter when the fixing centres are marked out.

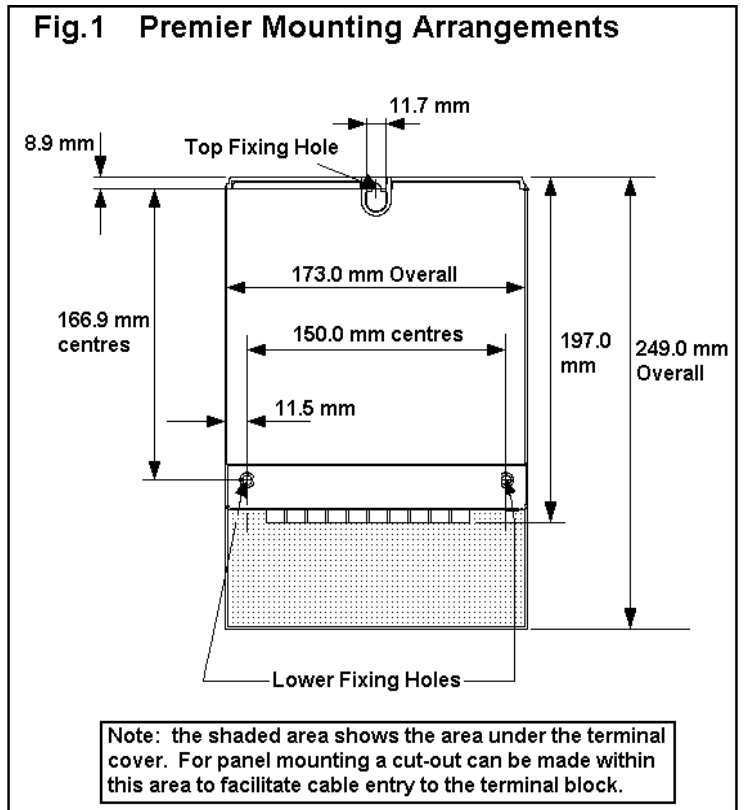

SECTION B: ELECTRICAL CONNECTIONS AND WIRING CONFIGURATIONS

Three Premier variants exist to cater for the most commonly encountered wiring configurations. Check that the meter supplied is suitable for the installation before making any connections. Note that there is no variant for connection to low voltage supplies that do not have a neutral connection.

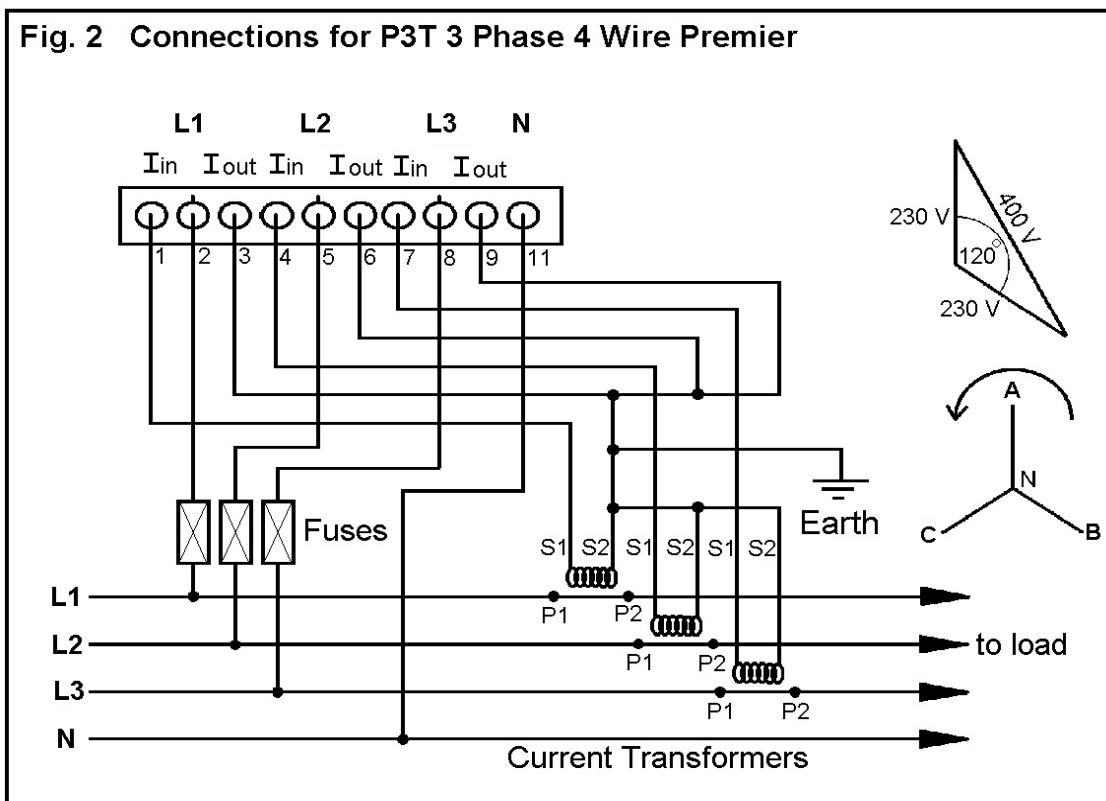
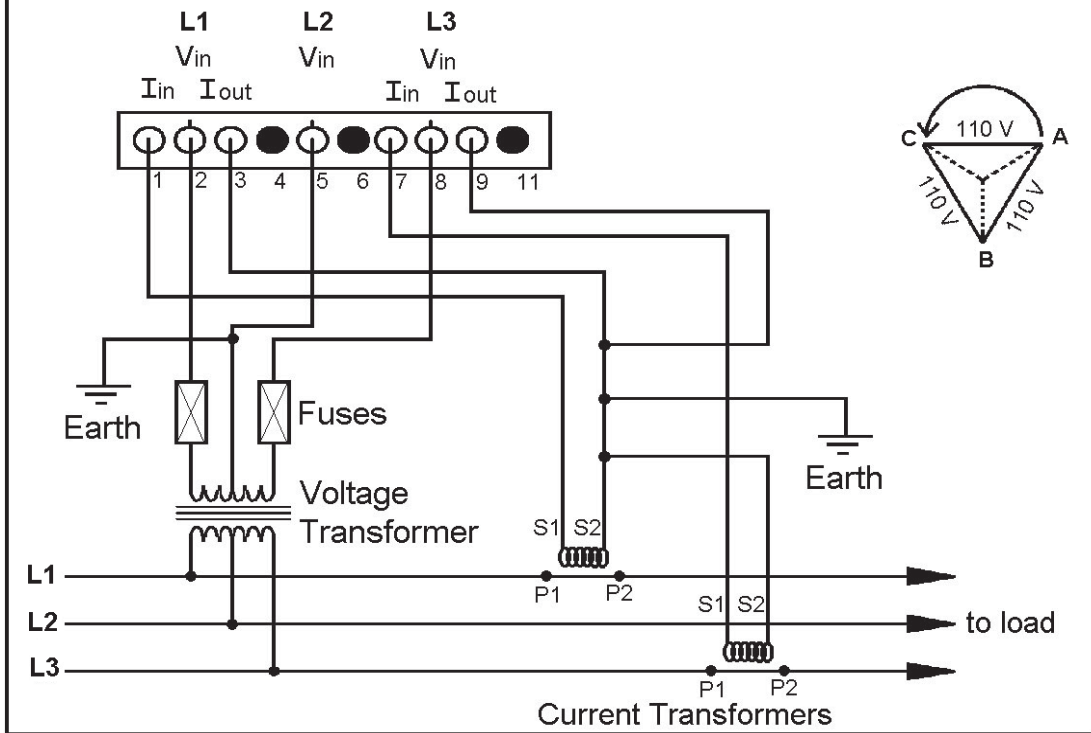
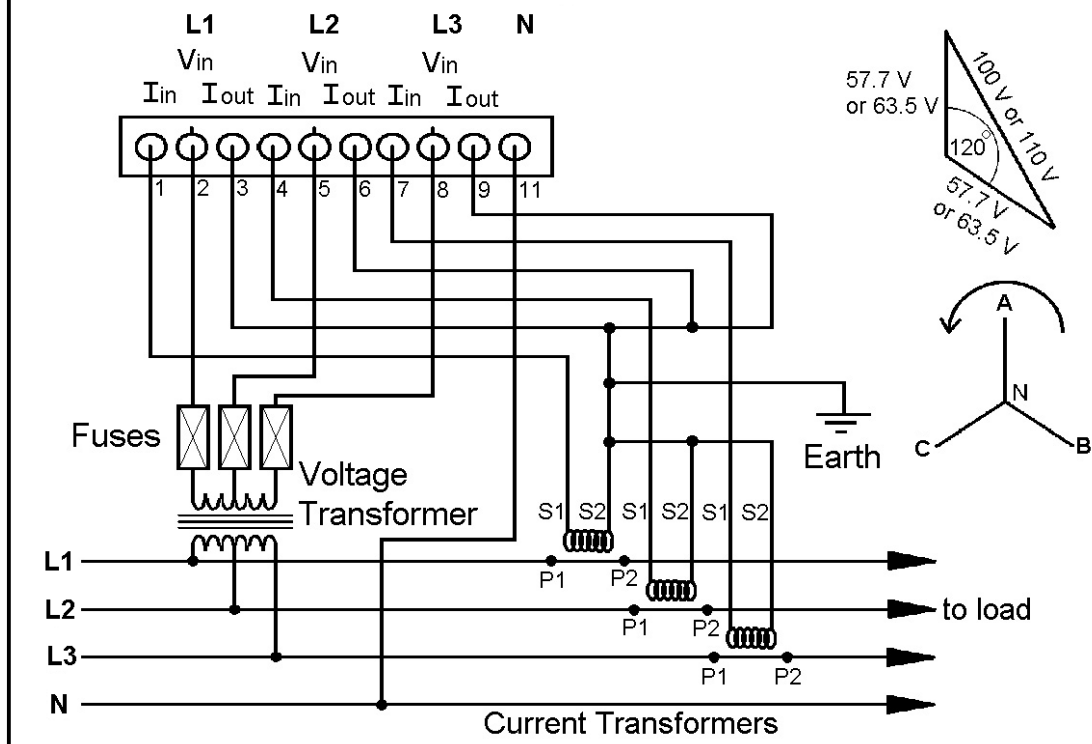

Fig. 3 Connections for P3V 3 Phase 3 Wire Premier



Special Note: For 3-Phase 3-Wire balanced installations correct operation can be achieved with only one voltage transformer. This is done by connecting the VT between L1 and L2, and taking its output to both the L1 and L3 voltage inputs on the meter. The L2 voltage input is connected to the grounded side of the VT in the usual way. The L1 CT input is connected in the normal way to a CT fitted around the L1 conductor. The L3 CT input is connected to a CT fitted *in reverse* around the L2 conductor. Refer to supplier for details.

Fig. 4 Connections for P3M 3 Phase 4 Wire Premier



SECTION C: FITTING CONDUCTORS

Local best practice must be observed when selecting conductor size and type.

All Premier models can accept cabling from 2.5 - 5.0 mm² conductor area, with external diameter up to 7.0 mm. The Premier is equipped with an extended terminal cover, and is intended to be used in installations in which all the cabling is concealed; it is not therefore necessary to use double-insulated cable.

The cables must be cut and trimmed carefully. The insulation must be cut back and removed 'squarely', ensuring that no copper is exposed on the portion of the cable outside the conductor bore. Particular care must be taken to ensure that all the conductor strands are contained within the conductor bore.

Approximately 20 mm of conductor should be cut back when the cable is trimmed.

The process for fitting the conductors is as follows:

1. Cut and trim the cables
2. Loosen the conductor screws fully
3. Insert the cable fully into the conductor bore, ensuring that no copper is exposed external to the meter
4. Tighten the conductor screws
5. Replace the terminal cover
6. Seal the terminal cover

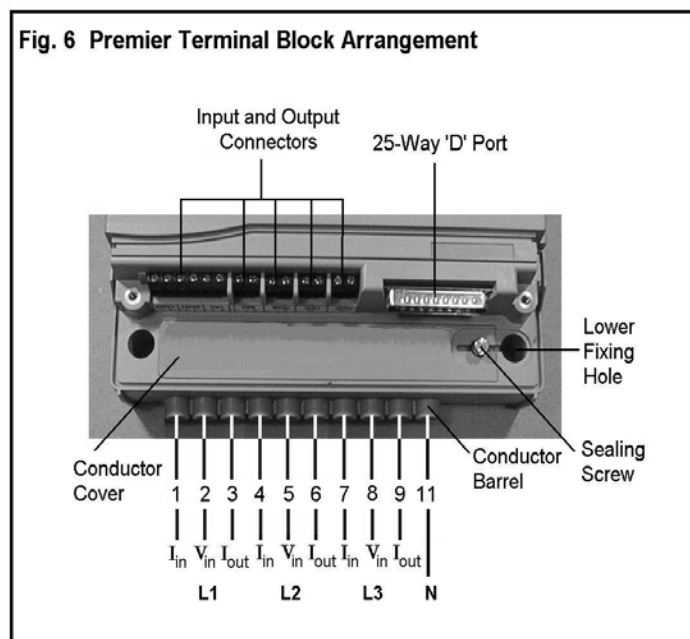

SECTION D: CONNECTING EXTERNAL INPUTS OR OUTPUTS

Premier meters can have a number of input and output connections under the main terminal cover. These are controlled by a combination of the CLEM operating program and the tariff configuration file loaded into the meter. The CLEM and tariff are indicated on the LCD screen (see section G for details). The input and output terminals can accept cable sizes of up to 2.5 mm². Pulsed inputs are rated for connection to voltages in the range 5 to 40 V dc. Pulsed outputs are rated for connection to voltages in the range 5 to 40 V dc, or to mains voltages up to 240 V ac. The number of inputs and outputs on a given meter is determined by the hardware build, as shown below.

Table 1: Input and Output Configurations

I/O Type	Outputs	Inputs
43	2 d.c. , 2 a.c. or d.c.	2 counting, 1 state-sensing
42	2 d.c. , 2 a.c. or d.c.	2 counting
40	2 d.c. , 2 a.c. or d.c.	None
24	2 a.c. or d.c. , 9 V wetting voltage	2 counting, 2 state-sensing
00	none	None

The I/O type can be determined by examining the part number printed on the ratings plate visible under the display window. See section I for details.

Note: The state-sensing inputs are only ever used for time or rate synchronisation with an external controller, and are not available as standard programming options.

The minimum pulse width for output pulses is 80 ms. The maximum theoretical pulse frequency is typically 1 Hz, but this is not possible for all primary scaled values.

The pulsed inputs can detect pulses of 50 ms minimum duration, at a maximum rate of 10 Hz.

The assignment of the pulsed outputs is determined by the tariff file loaded at manufacture. The standard options available are detailed in Table 4. The value of energy pulses is determined by the meter scaling, see section H for details.

Fig. 7 Premier Input / Output Types Identified by Part Number

43	Input Counter 1 2	State Sensing Input	Outputs 1 2 3 4
42	Input Counter 1 2		Outputs 1 2 3 4
40			Outputs 1 2 3 4
24	Input Counter 1 2	State Sensing Input 1 2	Wetting Voltage 9 V d.c.
			Outputs 1 2



-+ -+ -+ -+ -+ -+ -+ 5-40 V d.c.
 ~ ~ ≤ 240 V a.c.

Notes:

1. Take care to observe polarity when connecting inputs or outputs to external voltages.
2. Outputs are 'volt-free' open-collector type. An external voltage must be provided for correct operation. Take care to observe polarity when using 'diode-test' function of a DVM to test functionality.
3. Inputs are not 'self-wetting'. An external voltage must be provided for correct operation.

Fig. 8 Premier Input and Output Circuits

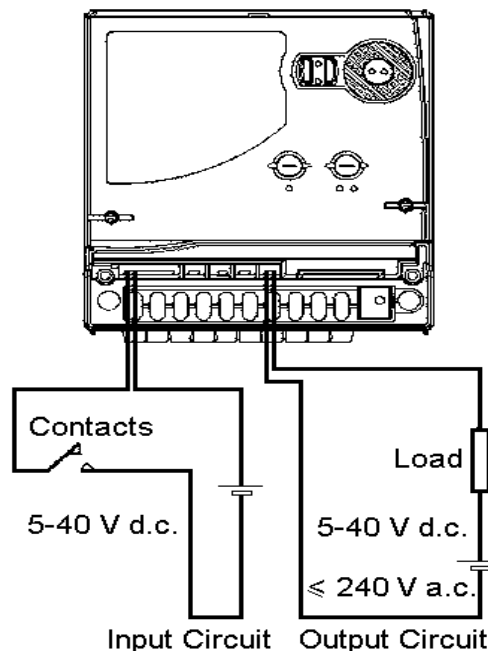

Special Note for Gas Metering:

A relay isolation unit may need to be fitted between the outputs of a gas meter and the inputs of the Premier meter. Contact your gas supplier for details.

SECTION E: COMMUNICATIONS

Premier meters are equipped with three communications ports. Two are mounted on the front cover, and one is under the terminal cover. All the communications ports use PRI's proprietary PACT protocol. This can be used to extract meter readings and half-hourly data using PRI software, or can be used to interrogate instantaneous parameters such as voltage, current, power etc.

The PACT port is a slot mounted on the front panel of the Premier, to which PACT probes can be fitted for local or remote comms.

The '1107' port is located to the right of the PACT port and takes the form of a standard magnetic annulus to which a local read probe can be attached.

The 25-way 'D' port is sited under the terminal cover and can only be accessed when the cover is removed. The 'D' port can be connected to a PRI 'integral' modem or can be used to interface with external telephone or radio systems. An external mains power supply must be used when connecting modems to Premiers that do not have 'M' at the end of the part number.

The default data rate for all the ports is 1200 bd, but the PACT port and 'D' port can be supplied to special order configured for 2400 or 4800 bd.

The tariff file loaded at manufacture determines how the load survey storage is set up. Table 4 shows the parameters stored, and the number of days stored, for each of the standard configurations. Note that tariff TARF does not support load survey.

Refer to supplier for details of load survey options.

Fig. 9 Premier Communications Ports

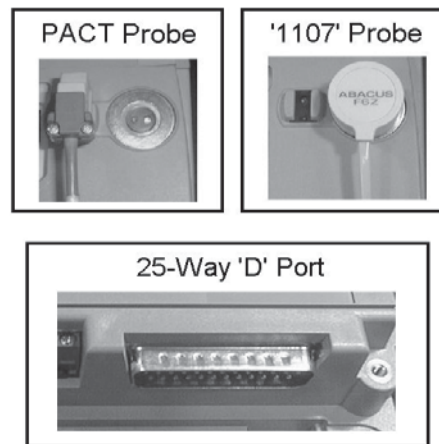

SECTION F: DISPLAY OPERATION

The Premier is equipped with an LCD window for displaying metering and status information.

The display is operated using the push buttons mounted on the front panel.

The right-hand button is used to actuate the display; each press advances the display by one position in the 'display sequence' programmed at manufacture.

The display sequence is split into a number of pages which are accessed in turn using the left-hand button.

The exact configuration of the display is determined by the combination of CLEM program and tariff file loaded into the meter at manufacture. Note that 'time-of-use' tariff rate registers, such as 'day' and 'night', are only displayed if implemented in the tariff loaded into the meter at manufacture. The default tariffs for each programming option do not include time-of-use tariff files, so the only rate register normally displayed is 'Rate 0', unless a particular tariff arrangement was specified at time of ordering.

Note that the 'Heathrow' specification includes two time-of-use registers; 'Rate 1' from midnight to 7 am and 'Rate 2' from 7 am to midnight.

This document covers the 'standard' configurations available from PRI, for 'Tariff', 'Profile', 'CoP5', 'Multi Utility', 'Heathrow' and 'KEMS' options.

Refer to supplier for details of programming configurations.



SECTION G: DISPLAY OPTIONS IN TARIFF

Table2. Display Availability for Typical Premier Programming Options

Display Number	Tariff	Profile & Code 5	Multi-Utility	Utility Manager	Heathrow Spec.
<i>Page 1</i>	TARF0001	PROF3010 & COP53010	UTIL3010	KEMS0001	LHRP0001
1	Active Rate	Active Rate	Active Rate	Test Pattern	Active Rate
2	Current Page	Test Pattern	Test Pattern	Total kWh	Test Pattern
3	Test Pattern	Current Page	Current Page	Input Count 1	Total kWh
4	Total kWh	Total kWh	Total kWh	Input Count 2	Total kVAh
5	Total kVAh	Total kVAh	Total kVAh	Time	Power Factor
6	MD kVA	Total kvarh	Total kvarh	Date	MD kVA
7	MD kW	MD kW	Input Count 1	Phase Presence	Rate 1 (00:00 to 07:00h)
8	Billing MD kVA	MD kVA	Input Count 2		Rate 2 (07:00 to 24:00h)
9	Billing MD kW	Billing MD kW	MD kW		MD reset count
10	MD reset count	Billing MD kVA	MD kVA		Time
11	Rate 1 etc.	Cumulative MD kW	Billing MD kW		Date
12		Cumulative MD kVA	Billing MD kVA		Primary Current
13		MD reset count	Cumulative MD kW		Primary Voltage
14		Time	Cumulative MD kVA		LED Scaling
15		Date	MD reset count		CLEM Name
16		Rate 1 etc.	Time		Tariff Name
			Date		
			Rate 1 etc.		
<i>Page 2</i>					
1	Current Page	Current Page	Current Page	Current Page	
2	Rising Demand kVA	Rising Demand kW	Rising Demand kW	Power Factor	
3	Rising Demand kW	Rising Demand kVA	Rising Demand kVA	Frequency	
4	Phase Presence	Power Factor	Power Factor	L1 Voltage	
5	Power Factor	Phase Presence	Phase Presence	L2 Voltage	
6	Frequency	Frequency	Frequency	L3 Voltage	
7	L1 Line Current	L1 Line Current	L1 Line Current	L1 Line Current	
8	L2 Line Current	L2 Line Current	L2 Line Current	L2 Line Current	
9	L3 Line Current	L3 Line Current	L3 Line Current	L3 Line Current	
10	L1 Voltage	L1 Active Current	L1 Active Current	CLEM Name	
11	L2 Voltage	L2 Active Current	L2 Active Current	Tariff Name	
12	L3 Voltage	L3 Active Current	L3 Active Current		
		L1 Reactive Current	L1 Reactive Current		
		L2 Reactive Current	L2 Reactive Current		
		L3 Reactive Current	L3 Reactive Current		
		L1 Voltage	L1 Voltage		
		L2 Voltage	L2 Voltage		
		L3 Voltage	L3 Voltage		
<i>Page 3</i>					
1	Current Page	Current Page	Current Page		
2	Time	Primary Current	Primary Current		
3	Date	Primary Voltage	Primary Voltage		
4	Primary Current	Test LED Value	Test LED Value		
5	Primary Voltage	Hi Res kWh	Hi Res kWh		
6	LED Scaling	CLEM Name	CLEM Name		
7	CLEM Name	Tariff Name	Tariff Name		
8	Tariff Name				

SECTION G1: DISPLAY FORMATS

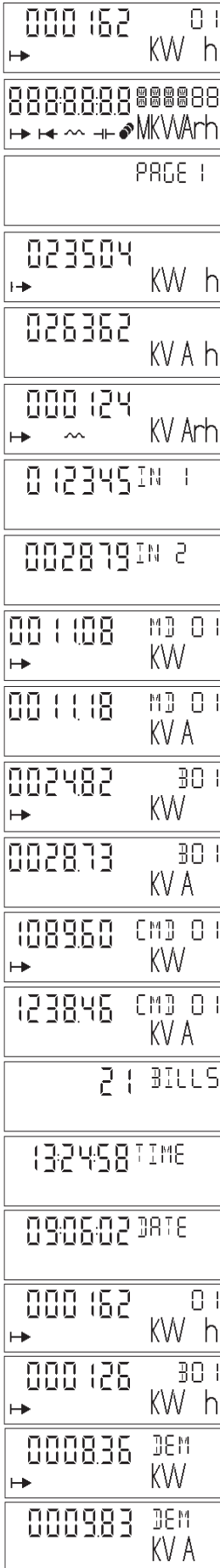

Active Rate: This display shows which tariff rate is active, together with the value accumulated in it.

Test Pattern: All segments illuminated.

Page Identifier: for Page 1, 2, 3 etc.

Total kWh: Shows total consumed active units since manufacture.

Total kVAh: Total apparent energy units since manufacture. Increments for imported or exported energy.

Total kvarh: Shows total reactive consumed (lagging) energy units since manufacture.

Input Count 1: Shows total number of pulses counted on input 1 since manufacture.

Input Count 2: Shows total number of pulses counted on input 2 since manufacture.

MD for kW: Shows kW maximum demand for current billing period. (Reset at the end of each month).

MD for kVA: Shows kVA maximum demand for current billing period.

Billing MD for kW: Shows kW maximum demand for previous billing period.

Billing MD for kVA: Shows kVA maximum demand for previous billing period.

Cumulative MD for kW: At the end of each month the value in the kW MD register is added to this register.

Cumulative MD for kVA: At the end of each month the value in the kVA MD register is added this register.

MD Reset Count: Shows the number of MD resets (monthly billing and presses of the MD reset button).

Time: In HH:MM:SS format, GMT only, no adjustment for summer time (BST).

Date: In DD:MM:YY format.

Rate Register 1: The units accumulated in tariff rate 01, 02 etc. For meters with more than one rate.

Billing Rate 1: Shows the units in accumulated in tariff rate 01, 02 etc 'frozen' at the last billing point.

Rising Demand for kW: Shows the kW demand for the current half-hour period. Reset every half-hour.

Rising Demand for kVA: Shows the kVA demand for the current half-hour period. Reset every half-hour.

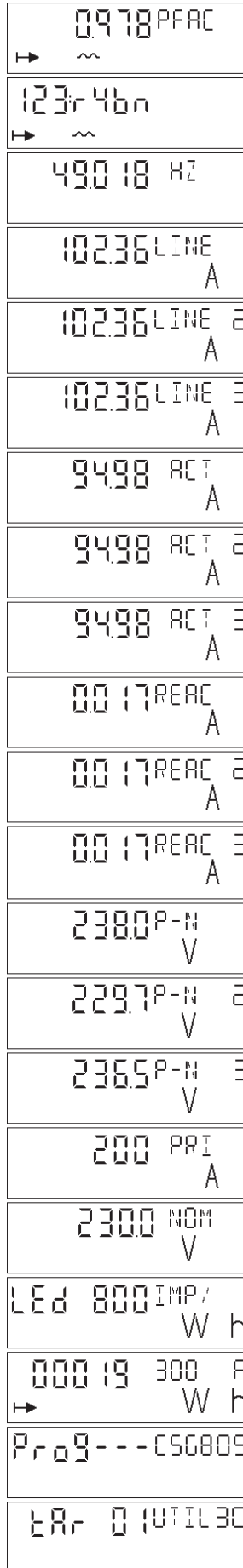

Power Factor: Instantaneous average three-phase power factor. A 'minus' sign indicates 'leading'.

Phase Presence: '123' indicates correct rotation. 'rybn' shows all phases present.

Supply Frequency: Instantaneous mains frequency, updated each second.

Phase 1 Line Current: Apparent current for L1, updated every second. Shows magnitude only.

Phase 2 Line Current: Apparent current for L2, updated every second.

Phase 3 Line Current: Apparent current for L3, updated every second.

Phase 1 Active Current: In-phase current for L1.

Phase 2 Active Current: In-phase current for L2.

Phase 3 Active Current: In-phase current for L3.

Phase 1 Reactive Current: Out-of-phase current for L1, updated every second. A 'minus' sign indicates 'leading'.

Phase 2 Reactive Current: Out-of-phase current for L2.

Phase 3 Reactive Current: Out-of-phase current for L3.

Phase 1 Voltage: For 3-phase 4-wire meters the L1 to neutral voltage is shown, updated every second.

Phase 2 Voltage: L2 to neutral voltage.

Phase 3 Voltage: L3 to neutral voltage. (3-phase 3-wire meters show phase to phase voltage).

Current Rating: The primary current to which the meter is scaled.

Voltage Rating: 3-phase 4-wire meters show phase to neutral voltage, 3-phase 3-wire HV meters show phase-to-phase.

Test LED Output Value: This shows the 'units per increment' for the LED activity indicator, e.g. 400 flashes per kWh.

High-Resolution Energy: Shows fractional units to a greater resolution than the total unit displays.

CLEM Program Name: Shows the 'family', 'variant' and the 'version'.

Tariff Configuration File: Note the order in which the characters are displayed. The example is for 'UTIL3001'

SECTION H: METER SCALING

Premier meters are configured at manufacture to suit the intended application. This includes programming arrangements for tariff as well for meter scaling. Premier meters are usually supplied with 'primary scaling' so that the metering values reported are scaled up to the level seen at the load. The scaling is fixed at manufacture and cannot be adjusted by the user. The primary current and voltage settings determine the rated power level for the meter. This in turn affects how demand and energy values are displayed and communicated.

The Premier display uses a combination of annunciator segments and zeroes to indicate whether the quantity is in Wh, 100 kWh, 10 MWh and so on.

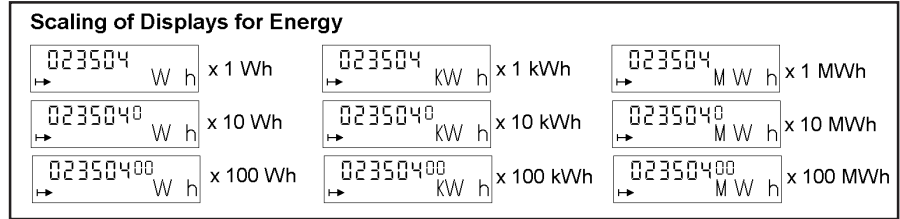

Meter scaling also affects the value of output pulses related to energy consumption and the value of 'units' communicated when the meter is read electronically.

The rated power for a Premier is calculated in the following way:

For 3p 3w meters (P3V) the rated power is ($\sqrt{3} \times$ (primary phase to phase voltage \times primary current))

Example: For an 11 kV, 100 A P3V the rated power is $1.732 \times 11,000 \times 100 = 1,905,255 \text{ W} = 1.905 \text{ MW}$

For 3p 4w meter (P3T or P3M) the rated power is ($3 \times$ (primary phase to neutral voltage \times primary current))

Example: For a 230 V, 100 A P3T the rated power is $3 \times 230 \times 100 = 69,000 \text{ W} = 69 \text{ kW}$

Example: For a 33 kV, 200 A P3M the rated power is $3 \times 33,000 \times 200 = 19,800,000 \text{ W} = 19.8 \text{ MW}$

Table 3. Relationship Between Various Factors and Rated Power

Power (up to)	7 kW	14 kW	24 kW	69 kW	138 kW	240 kW	690 kW	1.4 MW	2.5 MW	7.2 MW	14 MW	25 MW	36 MW
Units (k)	0.1	0.1	0.1	1	1	1	10	10	10	100	100	100	1,000
Default Pulses (k)	0.01	0.02	0.05	0.1	0.2	0.5	1	2	5	10	20	50	50
LED flashes per kWh	8000	4000	1600	800	400	160	80	40	16	8	4	1.6	0.8
MV-90 Pulse Multiplier	0.001	0.002	0.005	0.01	0.02	0.05	0.1	0.2	0.5	1	2	5	10

SECTION I: PART NUMBER SYSTEM AND PREMIER SPECIFICATION

Table 4. Load Survey and Pulsed Output Availability for Typical Programming Options

Tariff	TARF	PROF	COP5	UTIL	KEMS	LHRP
			Load Survey			
Number of Days	None	129 days	52 days	39 days	52 days	129 days
Parameter 1		kW	kW	kW	kW	kW
Parameter 2			kVA	kVA	Input 1	
Parameter 3			kvar	Input 1	Input 2	
Parameter 4				Input 2		
			Output Pulses			
Output 1	kWh	kWh	kWh	kWh	kWh	kWh
Output 2	kVAh	kVAh	kVAh	kVAh	kVAh	
Output 3		kvarh	kvarh	kvarh		
Output 4		MD Synch	MD Synch	MD Synch		

Dimensions	W 176 x H 250 x D 67 (mm)
Weight	1 kg
Enclosure	ABS / Polycarbonate
Protection	IP 51 UL 94 V0
Burden per Phase	(for 3 phase meter)
Current Circuits	< 0.5VA at 5A, UPF
Voltage Circuits	< 0.5 VA

